

AM-VH1 Series

Single Wall Exhaust Ventilator

AquaMatic's AM-VH1 ventilator is an exhaust only unit to be used over] non-grease producing equipment.

The AM-VH1 is a Type 2, wall mounted, single island or double island, exhaust canopy used for non-grease applications for the removal of steam, vapor, heat and odors where grease is not present.

FEATURES

- NSF Listed Product
- Excellent Exhaust Flow Rates
- Exceptional Capture and Containment of Cooking Vapors
- Wall, Single Island or Double Island Configurations
- 100% Type 304 Stainless Steel Construction
- Exposed Corners Ground and Polished to Match Grain of Ventilator
- Pre-punched Hanging Angles
- Factory Pre-wired Lighting Optional
- Aluminum Mesh Filters

OPTIONS

- Condensate Perimeter Gutter and Single Drain
- Perforated Linear Supply Air Plenum (PLS)
- Enclosure Panels to Ceiling
- Lighting:
 - Recessed Incandescent
 - Recessed Fluorescent
- Roof Top Packages
- Exhaust Fans
- Make-Up Air Units:
 - Untempered Units
 - Direct Gas Fired Heated Units
 - Indirect Gas Fired Heated Units
 - Electric Heated Units
 - Heating & Cooling Coils

AQUAMATIC'S INTEGRATED SYSTEM

AquaMatic® offers a total system to insure maximum installation and operating efficiencies. Components consist of the ventilator, fire system and electrical controls contained within an integral utility cabinet, and fan packages including exhaust, untempered and tempered make-up air packages. Also available are air purification and energy management systems. Fire suppression systems include final hookup and inspection. Call your AquaMatic Representative for more details.

PERFORMANCE DATA

| Loads | Configuration | Min Exhaust CFM/ft | Recommended Duct Sizing |
|-------|---------------|-----------------------|-------------------------|
|-------|---------------|-----------------------|-------------------------|

| | | | |
|-------------------------------|----------------|-----|---------------------------------------|
| Light - Ovens, Rotisseries | Wall Hood | 100 | Exhaust - Based on 1500 FPM |
| | 1 Piece Island | 100 | |
| | Wall Hood | 150 | |
| Heavy - Dishwashers | 1 Piece Island | 150 | |

SPECIFICATIONS

Application

The ventilator is NSF Listed for use over non-grease applications, specifically for the removal of steam, vapor, heat and odors. The ventilator shall be used over dishwashers, steam tables, ovens, steamers or kettles if they do not produce smoke or grease-laden vapors, subject to approval of the authority having jurisdiction.

Construction

The ventilator shall be 100% constructed of Type 304 stainless steel with #3 or #4 polish. Front seams shall be welded. All exposed corners shall be ground and to match the ventilator grain.

The ventilator shall be constructed to include:

- Exhaust duct collar 4" high with 1" flange.
- A minimum of four connections for hanger rods. Connectors shall have 9/16" holes pre-punched in 1 1/2" x 1 1/2" angle iron at the factory to allow for hanger rod connection by others.

Certifications

The ventilator shall be NSF Listed.

Documentation

Manufacturer shall furnish complete computer generated submittal drawings including ventilator section view(s), plan view(s), duct sizing, and CFM and static pressure requirements. Static pressure, air velocity and air volume requirements indicated on drawings shall be precise and accurate and ventilator shall preform to said specifications. Drawings shall be available to the engineer, architect and owner for their use in construction, operation and maintenance.

SECTIONAL VIEWS

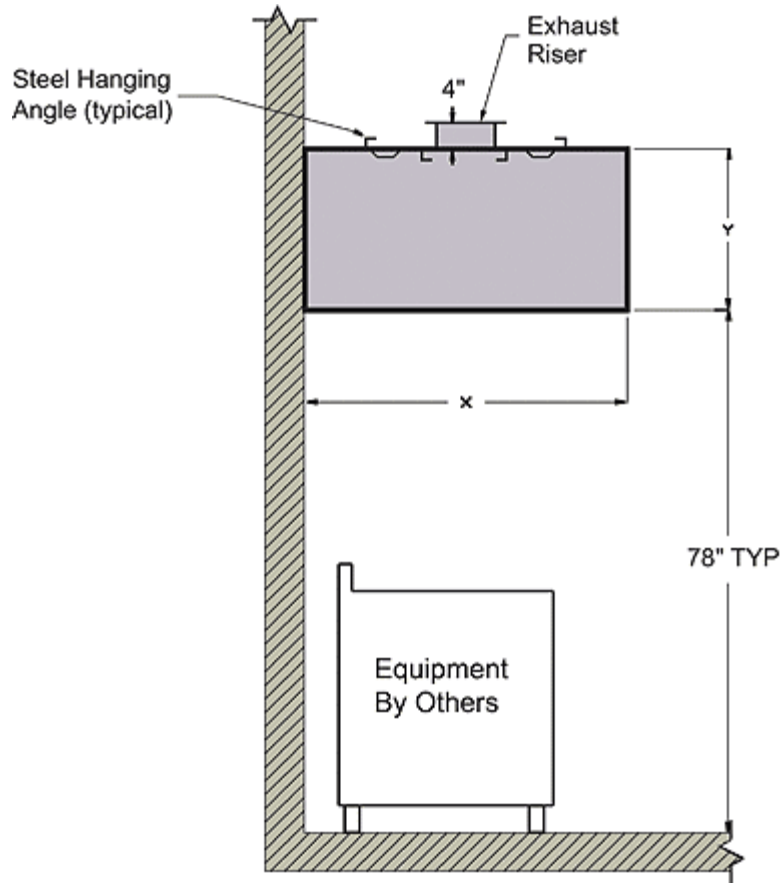

With Optional Perimeter Gutter

